

Automatic Marker

Model 800

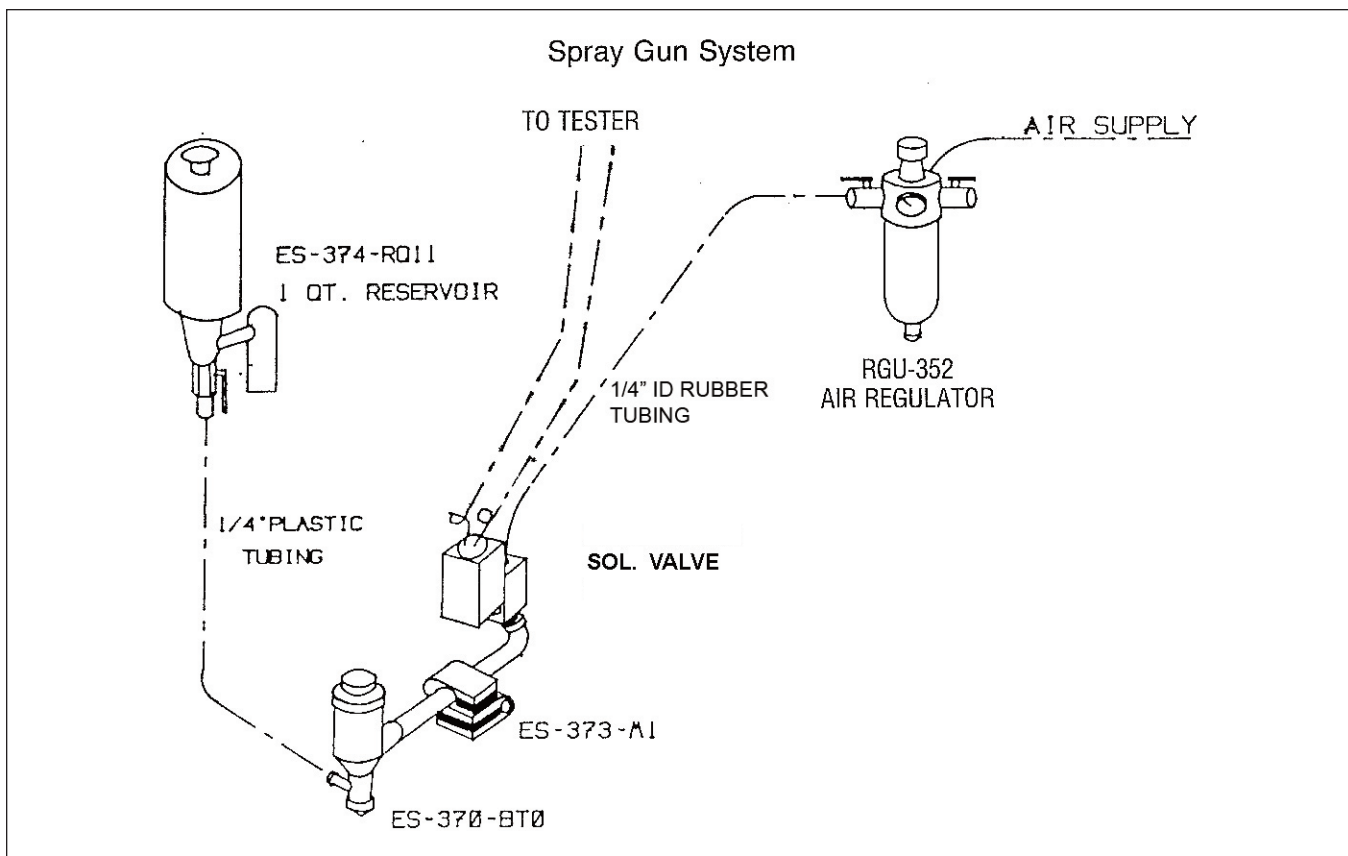

Application

The Model 800 spray marker is designed for use with MAC inspection systems. When the test equipment activates the solenoid valve of the marker, paint is sprayed. The activation time is adjusted by the test equipment. The size of the spray area can be varied by use of different size nozzles.

Description

The marker consists of a one quart capacity reservoir, with an inlet tube leading to a solenoid valve and then to the supply head. The supply head should be positioned between 1" (25.4mm) to 3" (76.2mm) from the material that is to be marked. Air pressure (40 to 80 PSI) aerates the spray and drives it onto the material.

A Filter/Regulator is included in the package to remove water that may be in the airline, and to control air pressure. The marker unit also includes a suitable plug-in cable for attachment to MAC inspection equipment.

Special fast drying ink, with good oil penetration and caustic bath resistance, is available directly from Carco, Incorporated, 10333 Shoemaker, Detroit Michigan 48213. Telephone 313-925-9000.

Utility Requirements

- Air Pressure: 80 PSI maximum input recommended
- Power: 24 Volts DC standard
120 VAC, 60 Hz, Single phase
240 VAC, 50/60 Hz, Single Phase

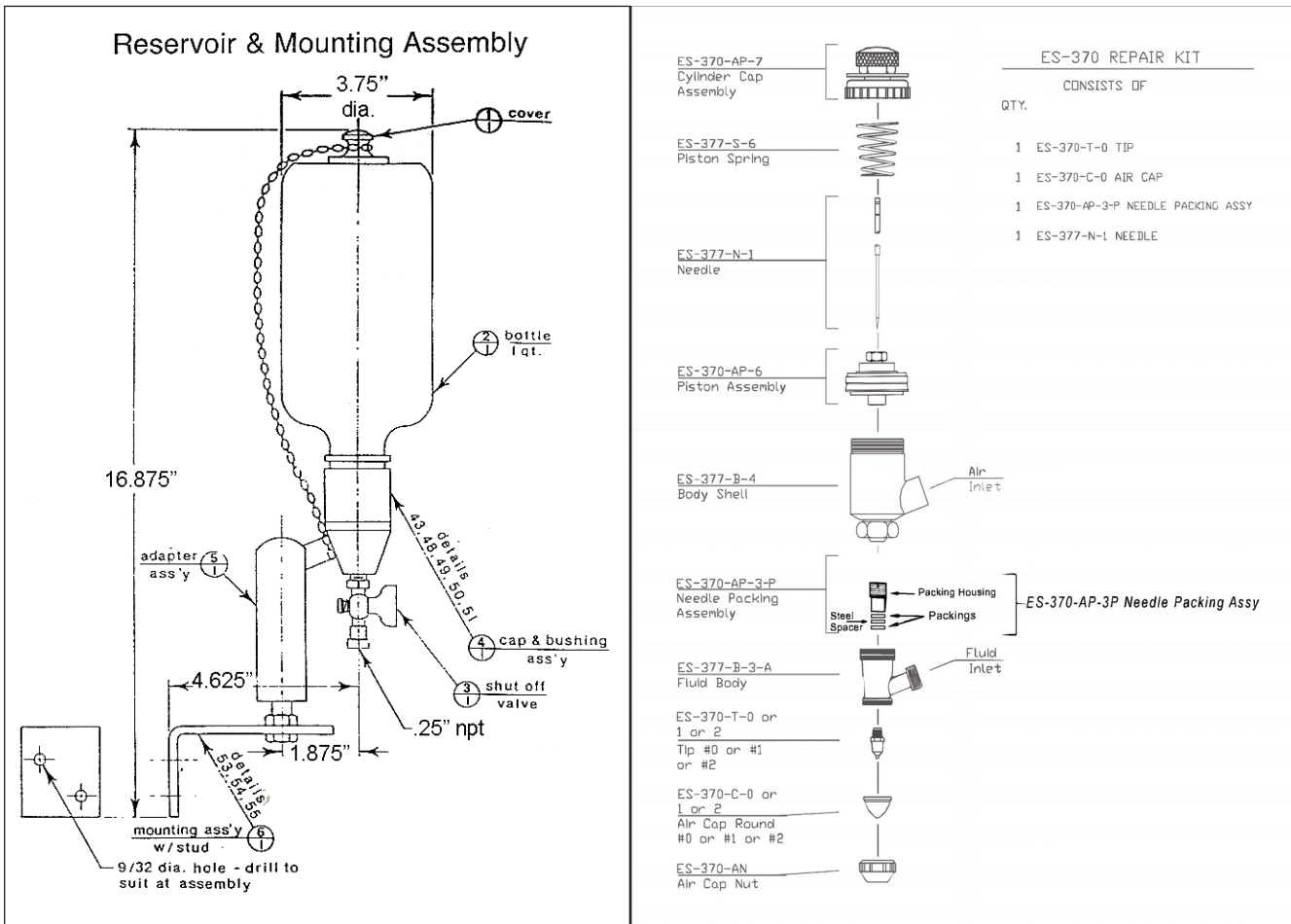

Magnetic Analysis Corporation ~103 Fairview Park Drive - Elmsford, New York 10523-1544 USA ~ Tel: +1.914.530.2000 ~ info@mac-ndt.com

www.mac-ndt.com